

X-Ray Baggage Scanner

SEC-100100D



Product highlights

- no generator, two view perspective dual energy imaging
- Multilingual operation
- Automatic built in test and self diagnosis
- Secure access Key
- Uninterruptable power supply(UPS)
- Threat alert and material classification
- Auto arching
- Network-Ready
- Energy saving design
- One key turn off
- Drugs and explosives inspection
- Indication of the date and time



Dimensional Drawing

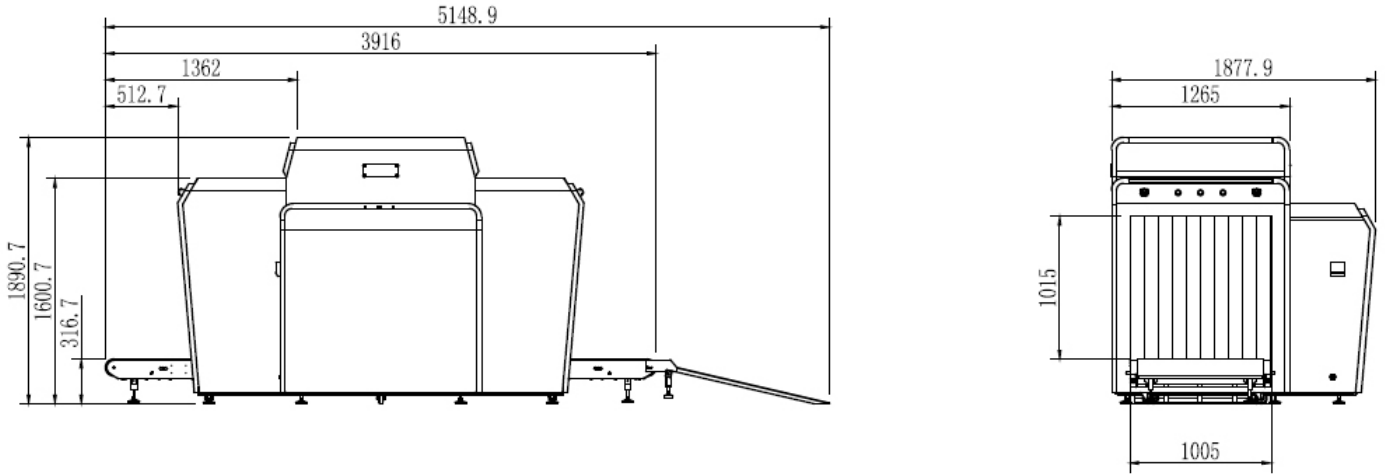

General Specifications

Model	SEC-10080D
General Specifications	
Wire Resolution	Typical AWG36(top view); Typical AWG36(side view)
Penetration resolution	Typical AWG30(top view); Typical AWG30(side view)
Spatial resolution	Vertical:1.3mm, horizontal:1.3mm(top view); Vertical:1.3mm, horizontal:1.3mm (side view)
Penetration	32mm(top view); 34mm(side view)
Resolution of organic matter	1 - 120 mm(top view); 1 - 120 mm(side view)
Grayscale and mixture resolution	1 - 60mm(top view); 1-60 mm(side view)
Resolution of inorganic objects	0.2-14mm(top view); 0.2-14 mm(side view)
Effective material resolution	Meet the requirements of GB15208.1-2005
X-Ray dosage each inspection	≤4.8 μSv(uGy)
Boundary Leakage	≤0.5 μSv /h(uGy/h)
S/N ratio	<60dB
Conveyor speed	0.2m/s
Conveyor max load	200kg
Power consumption	1.5KW
Safety performance requirements	Meet the requirements of GB 15208.1-2005
EMC requirements	Meet the requirements of G B 15208.1-2005
Electrical safety	Meet the requirements of G B 15208.1-2005



Environmental applicability	Meet the requirements of G B 15208.1-2005
Leakage current	≤5.0mA
Film Safety	Guarantee ASA / ISO 1600 Film
Weight	1350kg
Operation temperature/Humidity	5°C-40°C/0%-90%
Storage temperature/Humidity	-20°C-60°C /10%-90%
Atmospheric pressure	86kPa-106kPa
Operation Power	AC220V(±10%-15%) 50±3Hz
Operation system	Windows XP
General Specifications	
X ray generator	160KV, oil cooling, from top to bottom
Electric roller	Three-phase
Computer	CPU: Intel Celeron 2.70GHz, Hard drive: 500G, Storage : 2G
Monitor	17" LED screen, resolution: 1280*1024 pixels
Operation console	Double screen console
Software Functions	
Power-on self-test	With the function of fault self-check, automatically judge the fault and prompt the fault code information in time.
Image processing	With the function of Color/BW, negative, high/low penetration, organic /inorganic stripping, general enhancement, and pseudo color, etc.
Image Recall	30 preceding images recallable.
The number of images stored	Up to 10,00 images stored automatically
Image management	With the functions of image information query, open, export and print, 6 image formats can be exported (JPG, BMP, XF, PNG, TIFF, GIF)
Operator management	Operators can be added and deleted, and operator names, groups, passwords, enabled status can be modified, and usage logs can be exported.
Dangerous goods image insertion	TIP insertion pictures can be added and deleted, TIP enable status, injection interval, floating range,motion determination time, and stationary determination time can be set; the user can check the operator by recording information
Equipment diagnosis	Key components of equipment can be diagnosed through the diagnostic interface, including detector, motor positive and negative rotation, infrared sensor, special keyboard, etc.
System Settings	Programmable key, imaging display (horizontal, vertical image, maximum magnification, display recovery), scanning mode setting (two-way, direction, strong scanning, energy saving), auxiliary inspection(difficult to penetrate, explosives, drugs), luggage counter function Settings.

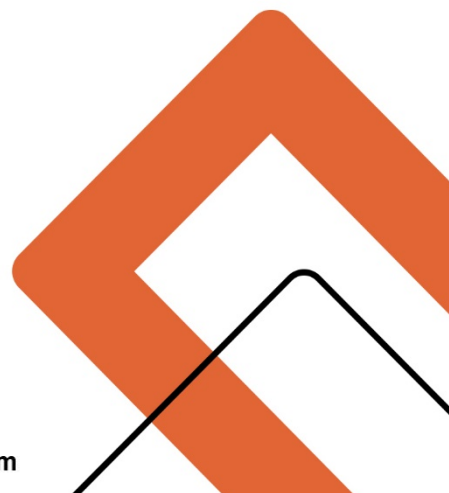

System equipment information	Display software version, equipment model, factory number, scan count, power on time, beam out time, image file storage capacity and other information. Able to conduct automatic through-baggage training for new operators.
Training function	Able to conduct automatic through-baggage training for new operators.
Compliance	
International	<ul style="list-style-type: none"> * ISO19001 ; ISO14001 ; ISO27001 ; OHSMS18001 ; * CE , ROHS, FCC, REACH * USA, FDA
National (China)	<ul style="list-style-type: none"> * Health Inspection Report * Computer Software Copyright Registration Certificate * Software Product Registration Certificate * Radiation Safety Certificate from Ministry of Public Security * Quality Certification from Safety and Police Electronic Products Quality Inspection Center * Design patent certification

Scanned images

